

# FITTING INSTRUCTIONS

## FIXED MOUNTING POINTS IN ROOFTOP CHANNEL

### 150 SERIES PRADO WAGON (LB43-01) TOUGH BAR - TLR14 & TLR13RM

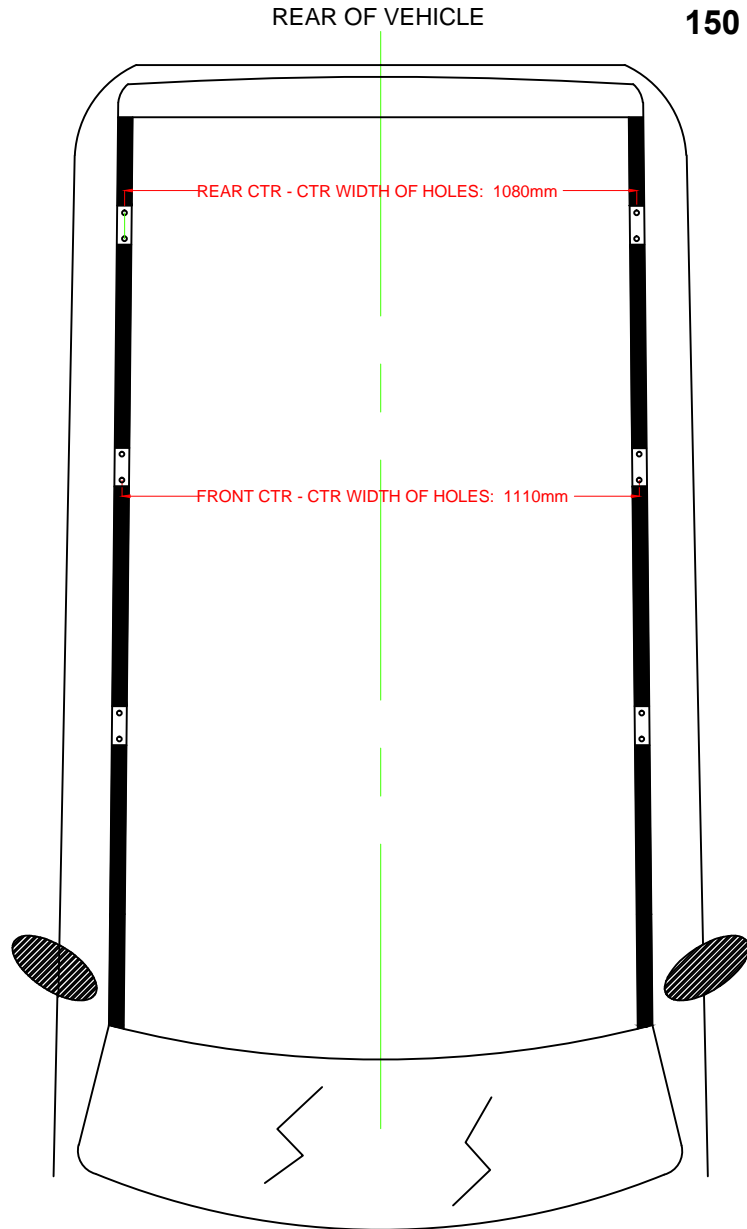

© JARAM AUSTRALIA 30-6-2020

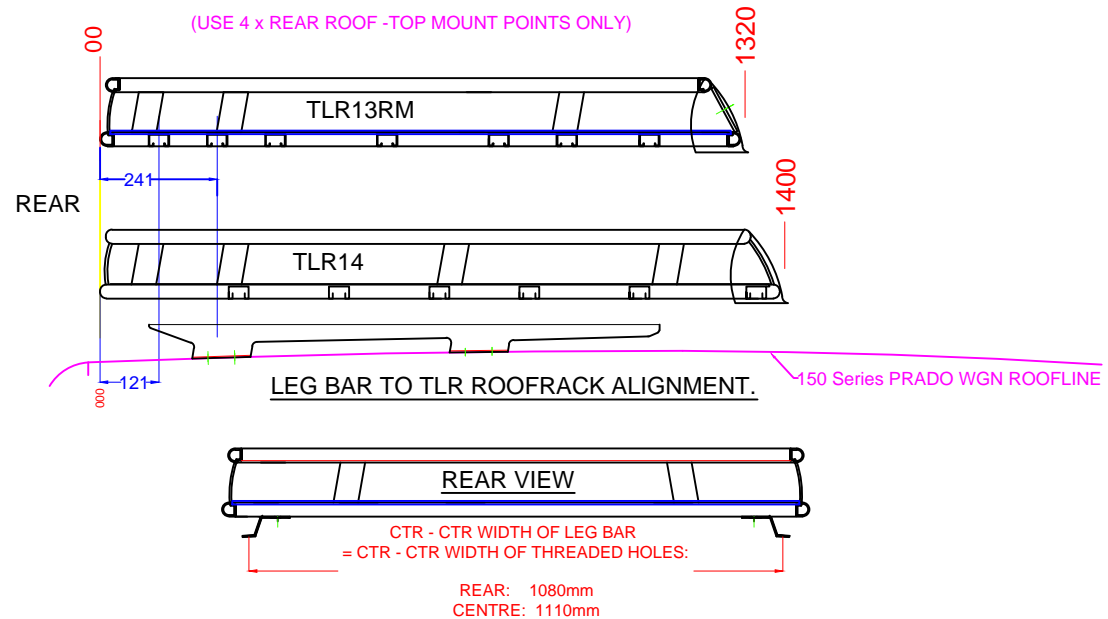

1. Remove 4 x Rear Cover Caps from the Rubber Strips on Roof Top. (2 x Caps on each side).
  2. Remove the Bolts and Metal Strap from the Threaded Holes in the cavities.
  3. Seal in and around the holes with Silicone Sealant and fit the Black Nylon Spacer Blocks over the holes.
  4. Measure the Centre to Centre width of the Threaded Holes at the REAR of vehicle and record the measurement.
  5. Measure the Centre to Centre width of the Threaded Holes at the CENTRE of vehicle and record the measurement.
  6. With the TLR Roof Rack upside down, position Tough Bars on the specific Channels, as shown. (Start from the Rear Position first).
  7. Secure with M10 x 25 Hex. Set Screw, Star Washer, Flat Washer and Channel Nut.
  6. Move the Tough Bars evenly both sides of Centreline to the Centre's of the Threaded Holes as shown.
- NOTE: Tough Bars must be equal distance from both sides of Roof Rack - Front and Rear.**
7. Tighten fasteners firmly to secure Tough Bars to Roof Rack.
  8. With a person either side of the Roof Rack, carry the Roof Rack over the rear of the vehicle and lower it gently on the Nylon Spacer Blocks and align the Hole Centres.
  9. Fit the M8x40 But. Soc. Screws with Flat Washer through Tough Bar Foot and into the Threaded Holes in Roof Top.
  10. Raise the rear Tailgate, check clearance from Roof Rack and tighten all Fasteners firmly.

NOTE: Check all Roof Rack and Tough Bar Fasteners regularly, especially after traveling over unsealed roads and rough terrain.  
30-6-2020 LMc.