



## INTERNAL CANOPY BARS FOR MAXI RACK & TRACKLANDER ROOF RACKS FITTING INSTRUCTIONS.

150Kg Load Rating  
on Bitumen Roads.

100Kg Load Rating  
Off Road.



### PREPARE AND DRILL HOLES IN UTE CANOPY.

1. With the Maxi Rack/Tracklander upside down, fit the (4) ICB Leg Mounts to the Crossbar Channels.

#### TYPICAL SET UP

2 x K ICBL40 (40mm high Leg Mounts fit to REAR Crossbar Channels).

2 x K ICBL60 (60mm high Leg Mounts fit to FRONT Crossbar Channels).

**NOTE: Leg Height Spacers may also have to be fitted to the front Leg Mounts to level the Maxi Rack.**

2. Adjust the width and centralise the Leg Mounts to the same hole centre's as the Internal Canopy Bar Top Crossbar Plates.
3. With (4) persons lift the Maxi Rack/Tracklander up and over the rear of the vehicle and lower it onto the Canopy rooftop with front of Maxi Rack/Tracklander facing forward. (Wind Deflector faces the front.)  
**NOTE: Support the front of the Maxi Rack/Tracklander with a cushion or rubber pad/block, to prevent the front of the Rack from damaging the Cab Roof.**
4. Lift and carefully centralise the Maxi Rack/Tracklander left to right.
5. Move Maxi Rack/Tracklander forwards or backwards to the best mounting position. Lift the Canopy Rear Door to check the clearance from the rear of the Maxi Rack/Tracklander. Note down the position of the Leg Mounts then check inside to see if the area is clear of any obstructions, bumps or hollows.



K ICBL40 - REAR LEG MOUNT POSITION



K ICBL60 - FRONT LEG MOUNT POSITION



# INTERNAL CANOPY BARS FOR MAXI RACK & TRACKLANDER ROOF RACKS FITTING INSTRUCTIONS.

6. Mark hole positions of the (4) Leg Mounts and check position again.
7. Remove the Maxi Rack/Tracklander from the Roof Top and pilot drill  $\varnothing 3\text{mm}$  hole through the Canopy
8. Hold up the ICB Crossbar inside the Canopy and check that the Top Cleat holes align with the holes in the roof.
9. Check that alignment is OK, and then enlarge the Holes in the Roof Top to  $\varnothing 8\text{mm}$ .

## FITTING - INTERNAL CANOPY BARS.

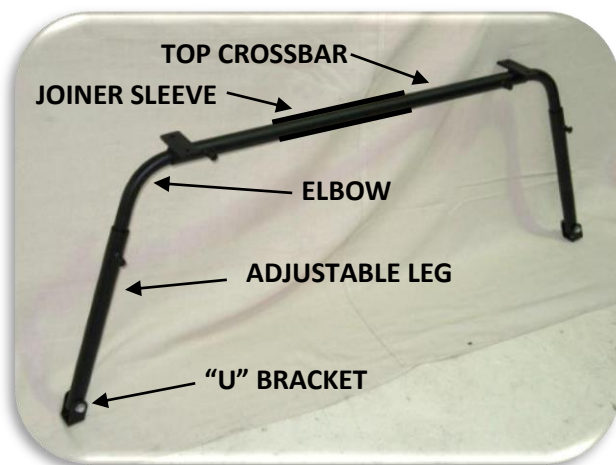

SINGLE INTERNAL CANOPY BAR  
TO SUIT WELL BODY UTE



SINGLE INTERNAL CANOPY BAR  
TO SUIT FLAT TRAY-BACK UTE

1.1 Fit the ICB Elbows into the Crossbar Tube.

**NOTE:** If the ICB Cross Bar is too wide, remove the pair of Crossbar Tubes from the Joiner Sleeve and trim the Inner Ends to reduce the length.

1.2 Hold the ICB Crossbar Tube (with the Elbows pushed in fully) up to the inside of the Canopy Roof and align with the holes. Fit the M8 x 40 Hex. Set Screws temporarily in the holes to hold the Crossbars in place.

**NOTE:** The Crossbar is best held in position with an Adjustable Stand or a Hydraulic Car Jack with a length of timber cut to suit.

### OPTION 1.



ICB ADJUSTABLE STAND –  
(To hold ICB in place while installing)

### OPTION 2.

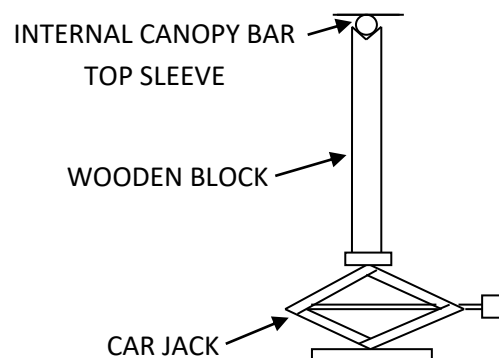



## **INTERNAL CANOPY BARS FOR MAXI RACK & TRACKLANDER ROOF RACKS FITTING INSTRUCTIONS.**

**1.3** Fit the Adjustable Legs to the Elbows, with "U" Brackets attached to the bottom end. Pivot the Adjustable Leg and "U" Bracket to a suitable position, which allows you to fix the "U" Bracket through the top edge of the well body, existing Canopy fixing bolts or Well body floor.



**CROSSBAR SLEEVE fixed to inside of CANOPY ROOF.**



**ADJUSTABLE LEG secured in place by "U" BRACKET by using existing fixing**



**Rear INTERNAL CANOPY BAR fitted to well body Ute.**

**1.4** With the mounting position established, increase the pressure upwards, until the Crossbar is pushed firmly against the roof, and then tighten all locking bolts firmly.

**1.5** Remove the temporary M8 x 40 Hex. Set Screws from the holes in the Canopy roof top.

**1.6** Seal around the holes on the outside and inside of the roof top with Sikaflex Sealant 252 Adhesive.

**1.7** Fit the Rubber Pads to the Leg Mounts on the Maxi Rack/Tracklander.

**1.8** With (4) persons, lift the Maxi Rack/Tracklander over the rear of the vehicle and lower it gently onto the Canopy Roof Top, aligning the Leg Mounts with the holes.

**1.9** Fit the M8 x 40 Hex Set Screws with flat washers through the holes on the top. On the inside fit the Flat Washers and Nyloc Nuts.

**1.10** With the Maxi Rack aligned with the vehicle, tighten all the Roof Top fasteners firmly and remove any excess Sikaflex Sealant.

