

Tough Bar X for canopy

(XLBKIT138-2) to suit TLRAL18FT

(XLBKIT138-3) to suit TLRAL22FT

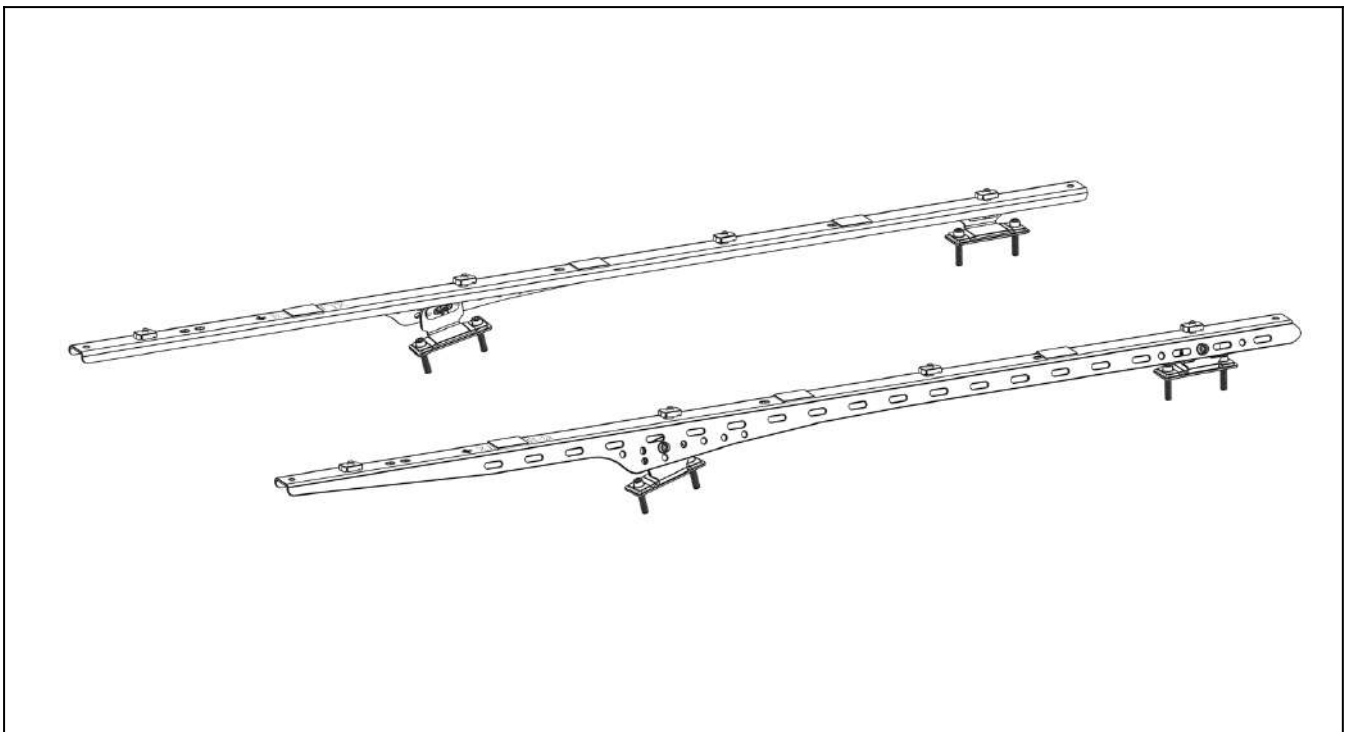

Thank you for purchasing a TRACKLANDER 4WD ROOF RACK. Before you start, take a moment to familiarise yourself with the Fitting Instructions and the components received. Refer to the next section for a list of all the components, quantities and tools required.

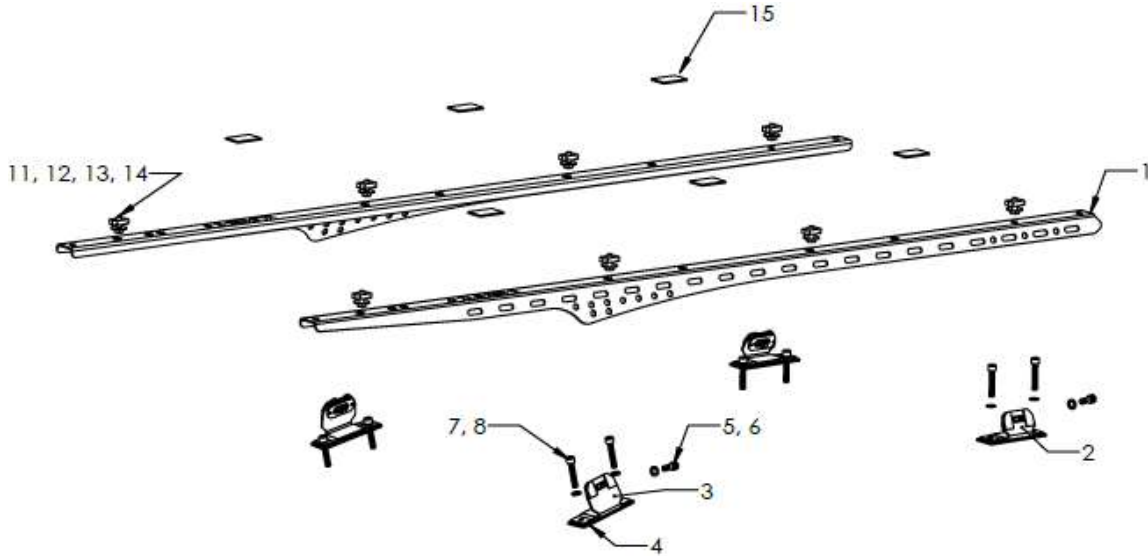

What's inside the box



No	Part Number	Description	Qty
1	XLB138-2 or XLB138-3	Tough Bar for canopy	1 pair
2	XAB138-Rr	X Bracket Rear	1 pair
3	XAB138-Fr	X Bracket Front	1 pair
4	XAB138-RP3	EPDM Rubber Pad, 3mm	4 pcs
X Bracket Fastener Kit			
5	FKIT X-Bracket	M10 x 30mm Socket Head Shoulder Screw, SS	4
6		$\frac{3}{8} \times \frac{3}{4}$ Flat Washer, SS	4
7		M8 x 30mm Socket Head Shoulder Screw, SS	8
8		$\frac{5}{16} \times \frac{3}{4}$ Flat Washer, SS	8
*9		M8 Nyloc Nut, SS	8
*10		$\frac{5}{16} \times \frac{1}{4}$ Flat Washer, SS	8
X Bar Fasteners Kit			
11	FKIT 1	M10 x 25mm Hex Bolt, SS	8
12		M10 Strut Nut, ZP	8
13		M10 Star Washer, SS	8
14		$\frac{3}{8} \times \frac{1}{4}$ Flat Washer, SS	8
Misc			
15	Acoustic Pad	30 x 60mm Acoustic Tape	6

Note: *9 & *10 not shown in the illustration. Requires only for direct mounting onto steel top canopy

Tools required
5mm Hexagon Wrench/Key, M8
8mm Hexagon Wrench/Key, M10
Size 17mm Spanner
Measuring Tape
Diameter 10 Drill
Pilot Drill (Diameter ¼" or 6.35mm)
Held Hand Drill Set

Recommended Torque Setting for fasteners	
M8	
M10	

Introduction

TLR138 is a versatile TOUGH BAR X design to suit most UTE canopy in the market. They are to be paired with either the Tracklander Flat Roof Rack, Red Dirt Mine Bar HD or Red Dirt AeroBar of your choice.

Please select the configuration below based on your canopy type:

- Steel Top UTE Canopy: XLB138 will be mounted directly onto the canopy top
- Fibreglass UTE Canopy: VERSA Internal Canopy Bar is required (Sold separately)

Fitting: Setting up Tough Bar on the Canopy

Type 1: Steel Top Canopy (Direct Mount)

With the X Brackets installed onto the Tough Bar X, position them onto a desired location on the canopy.

Note:

1. The pair of Tough Bar should be spaced as wide as possible on the canopy top.

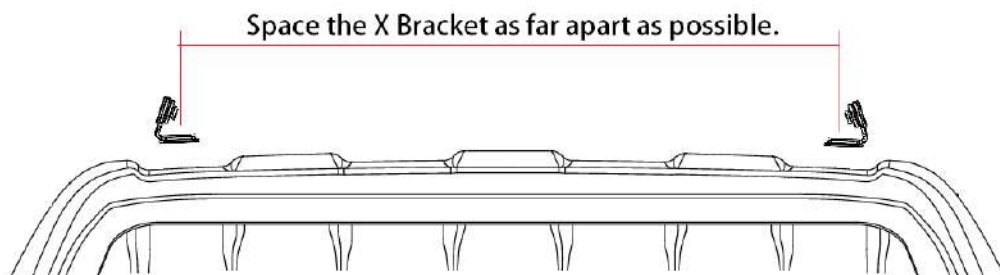

2. Always position the Brackets on a flat surface of the canopy.

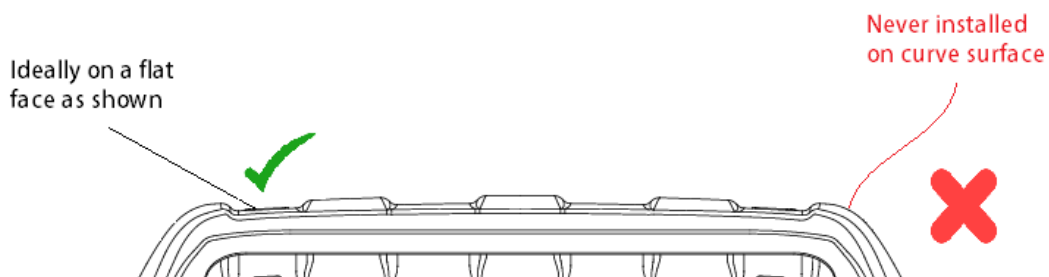

3. Tough Bar must be centralised to the mid plane of the canopy.

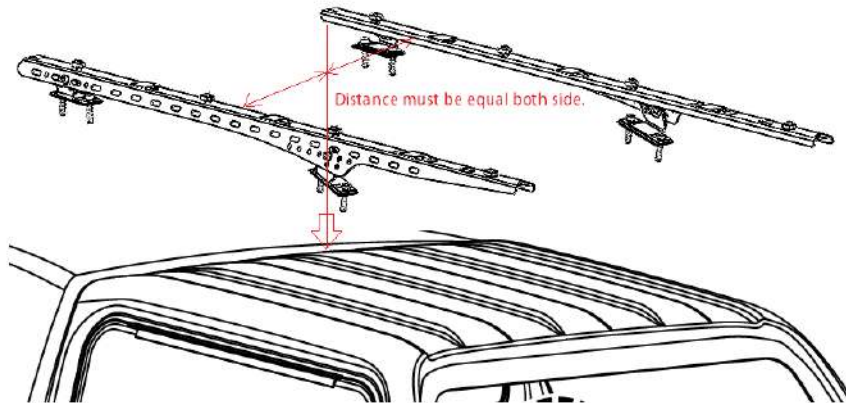

4. The Roof Rack must be parallel or slightly incline toward the front of the vehicle when they are not loaded (Approximately 1 degree)



5. Once the desired position of the X Brackets are determined, mark and drill through the canopy. Always starts with a pilot drill before finishing up the through hole with a diameter 10mm drill bit.

6. Install the X brackets onto the canopy as shown below:



7. Determine distance X & Y.
8. Setup the Tough Bar on the roof rack according to the measured distance X & Y with respect to the corresponding holes that are used to determine the mounting holes on the canopy.
9. Attached the Wind Deflector before mounting the fully assembled roof rack onto the X bracket.

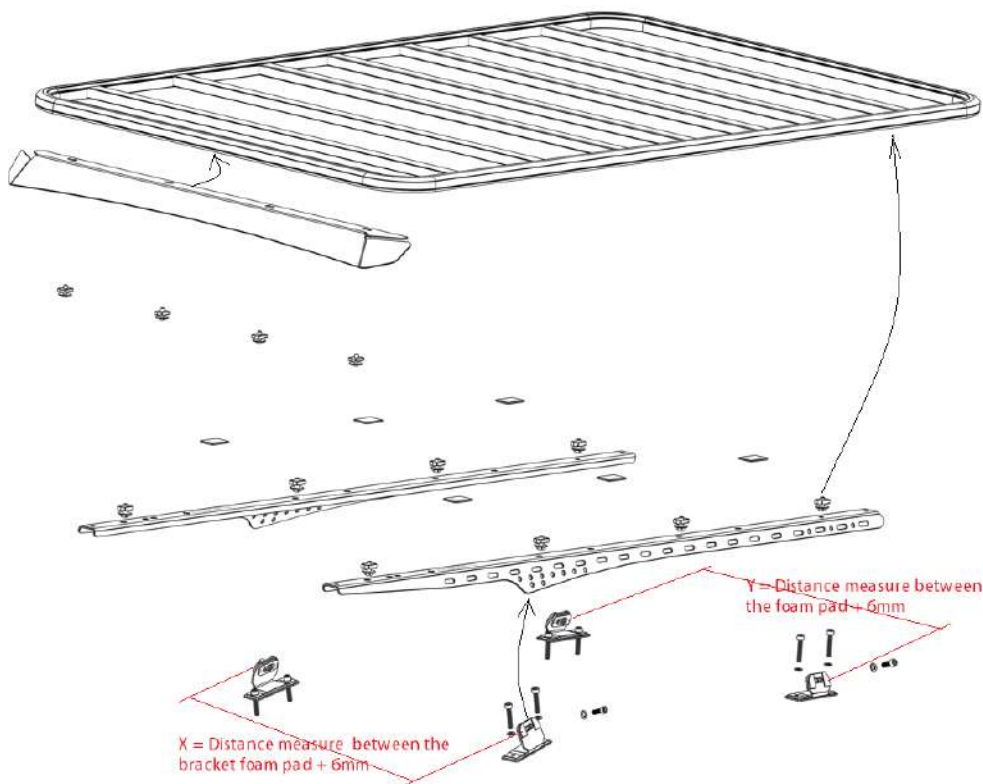

10. Check all fasteners for tightness and make sure that there is at least 20mm gap between the top of the vehicle and tip of the Wind Deflector.
11. Once done, the installation is completed.

Type 2: Fibreglass Canopy Top

Replace Step 6 with the following:

- Instead of mounting the X Bracket directly onto the canopy, they will be mounted onto the X-Bracket receiver found on the VERSA Internal Canopy Bar.
- Apply silicon generously around the drilled holes on the canopy to prevent water intrusion.
- Discard the M8 x 30mm Socket Head Cap Screws and replace it with the M8 x 60mm Socket Head Cap Screws that are supplied together with the VERSA Internal Canopy Bar Kit. (Apply silicone on the screw thread before installation)

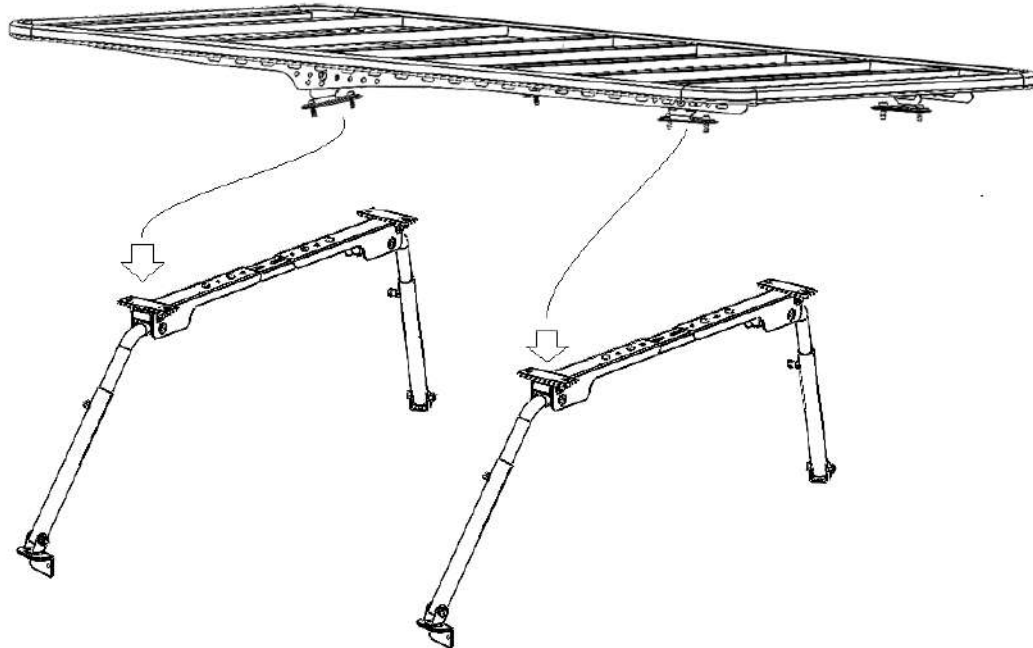

- Continue Step 7 to 11 per stated in page 6 and 7.

***Note: Fitting Instruction of the VERSA Internal Canopy Bar can be found within the product package separately.

SAFETY

- Cargo must be secured firmly onto the Roof Rack during operation at all times.
- Frequently check the tightness of cargo on the Roof Rack, especially when travelling over rough terrain or off-road
- Use only non-stretchable fastening ropes or straps to attach cargo onto the Roof Rack.
- Extreme care must be taken in off road conditions.

MAINTENANCE

- All bolted connections should be checked after driving a short distance when you first install your roof racks
- All bolted connections should be checked at regular intervals, depending on road conditions, usage, loads and distances travelled
- All bolted connections should be checked each time they are re-fitted.



IMPORTANT WARNING!

IT IS CRITICAL THAT ALL TRACKLANDER 4WD ROOF RACK PRODUCTS BE PROPERLY AND SECURELY ASSEMBLED AND ATTACHED TO YOUR VEHICLE. IMPROPER ATTACHMENT COULD RESULT IN AN VEHICLE ACCIDENT, AND COULD CAUSE SERIOUS BODILY INJURY OR DEATH. YOU ARE RESPONSIBLE FOR ASSEMBLING AND SECURING ALL TRACKLANDER 4WD ROOF RACK PRODUCTS TO YOUR VEHICLE, CHECKING THE ATTACHMENTS PRIOR TO USE, AND PERIODICALLY INSPECTING THE PRODUCTS FOR ADJUSTMENT, WEAR AND TEAR. THEREFORE, YOU MUST READ AND UNDERSTAND ALL OF THE INSTRUCTIONS AND PRECAUTIONS SUPPLIED WITH YOUR TRACKLANDER 4WD ROOF RACK AND ACCESSORIES PRIOR TO INSTALLATION OR USE. IF YOU DO NOT UNDERSTAND ALL OF THE INSTRUCTIONS AND WARNINGS, OR IF YOU HAVE NO MECHANICAL EXPERIENCE AND ARE NOT THOROUGHLY FAMILIAR WITH THE INSTALLATION PROCEDURES, YOU SHOULD HAVE THE PRODUCT INSTALLED BY A PROFESSIONAL INSTALLER OR OTHER QUALIFIED PERSON.

NOTE: TRACKLANDER 4WD ROOF RACKS will not be responsible for any damage caused by the failure to install the product according to these instructions. Please call us if you have any questions about the installation of this product.

TRACKLANDER 4WD ROOF RACKS

T : (08) 9451 0700 **E** : sales@tracklander.com.au **W** : tracklander.com.au
A: 12 Railway Parade, Welshpool, WA 6106
OPEN 8.00AM - 5.00PM MON-FRI