

300 SERIES TOYOTA LANDCRUISER WAGON

ROOF RACK(TLRAL22/FT/OE)

WIND DEFLECTOR(TLRWD15X)

TOUGH BAR(XLBKIT150-03X)

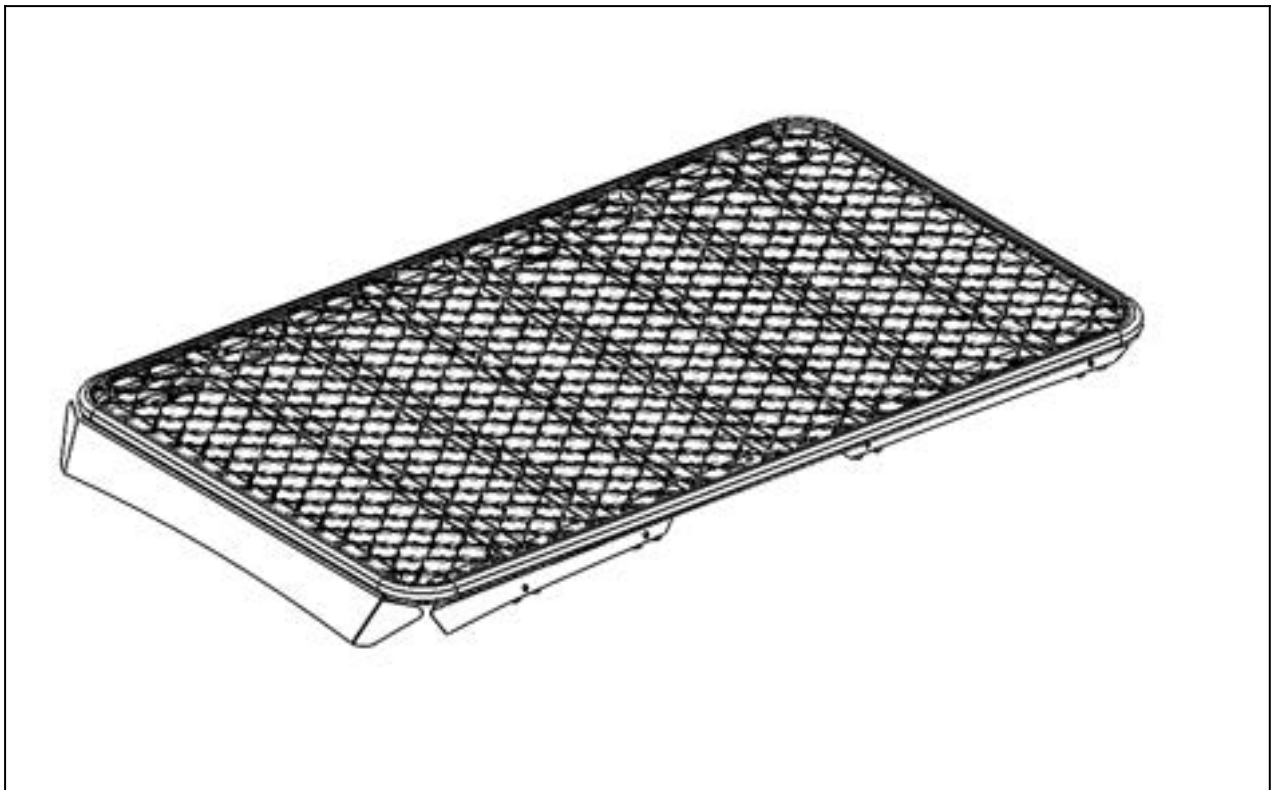

Thank you for purchasing a TRACKLANDER 4WD ROOF RACK. Before you start, take a moment to familiarise yourself with the Fitting Instructions and the components received. Refer to the next section for a list of all the components, quantities and tools required.

What's inside the box

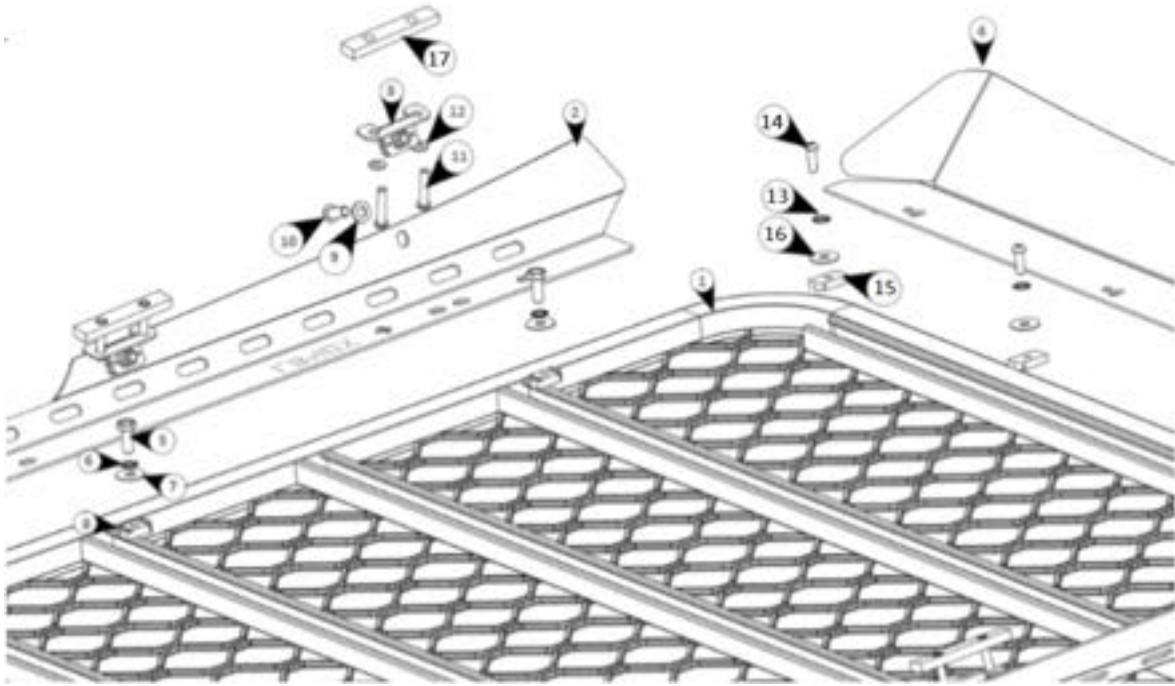



Note: Not all listed items below are supplied if purchasing Tough Bar Only)

No.	Description	Qty
*1	Roof Rack(TLRAL22/FT/OE)	1
2	Tough Bar X(Pair-XLB150)	1
3	X-Bracket Quick Fit Kit (**XAB40 x 06pcs, XAB40-LCR x 02pcs)	8
*4	Wind Deflector(TLRWD15X)	1
Tough Bar Fastener Kit		
5	M10 x 25mm Hex Bolt, S/S	8
6	M10 Star Washer, S/S	8
7	$\frac{3}{8}$ x $1\frac{1}{4}$, Flat washer, S/S	8
8	M10 Strut Nut,	8
X Bracket Fastener Kit		
9	$\frac{3}{8}$ x $\frac{3}{4}$ Flat Washer, S/S	8
10	M10 x 25mm Button Cap Socket Head Screw, SS	8

11	M8 x 50mm Button Cap Socket Head Screw , S/S	16
12	$\frac{5}{16}$ x $\frac{3}{4}$, Flat Washer, S/S	16
Wind Deflector Fastener Kit		
*13	M8 Star Washer, S/S	4
*14	M8 x 25mm Button Cap Socket Head Screw, S/S	4
*15	M8 Strut Nuts, Z/P	4
*16	$\frac{5}{16}$ x $1\frac{1}{4}$, Flat washer, S/S	4
Misc		
17	Black HDPE Spacer Block (TLRSP72XC)	8
Foam Pack		
#18	Foam Tape(60x40x2.5mm)	6
#19	Bracket Foam Pad	8
#20	Acoustic Foam Tape, (1100mm, FS126-9)	2

Note: *1, *4, *13, *14, *15 & *16 & #20 are provide only for purchase of a complete kit
 #18,#19 & #20 are not shown in the picture

Tools required
5mm Hexagon Wrench/Key, M8
6mm Hexagon Wrench/Key, M10
Size 17mm Spanner
Measuring Tape
Silicon Sealant

Recommended Torque Setting for fasteners	
M6	
M8	
M10	

Step 1: INSTALLATION OF X-BRACKETS

A. Remove the following items from the roof ditches:

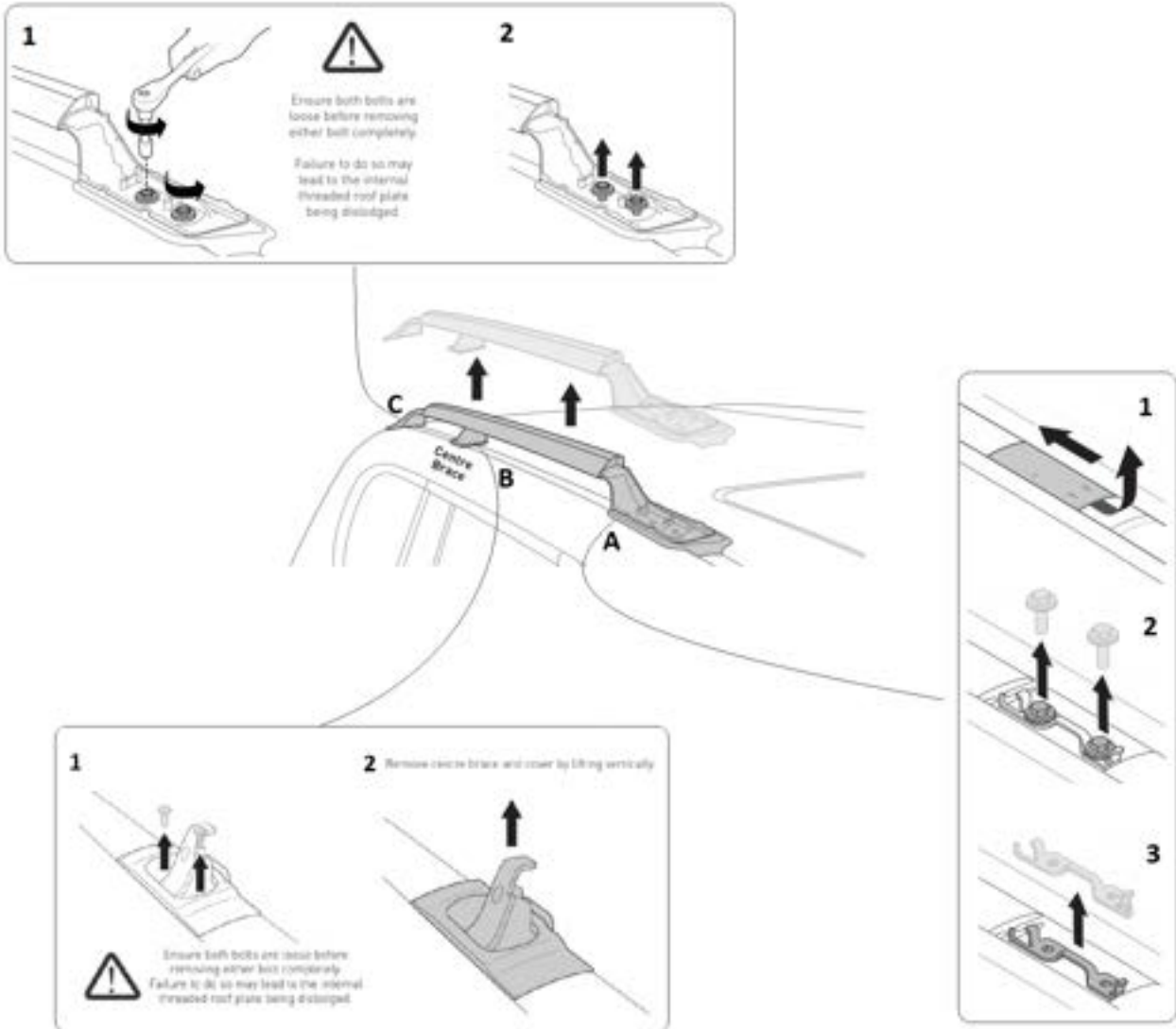

- Store the removed hardware in Glove Box (You may need them should you restore back to factory default configuration in future)

B. Seal around the holes with Silicone Sealant

*Note: Extra care needed to ensure adequate amount is applied for proper sealing.

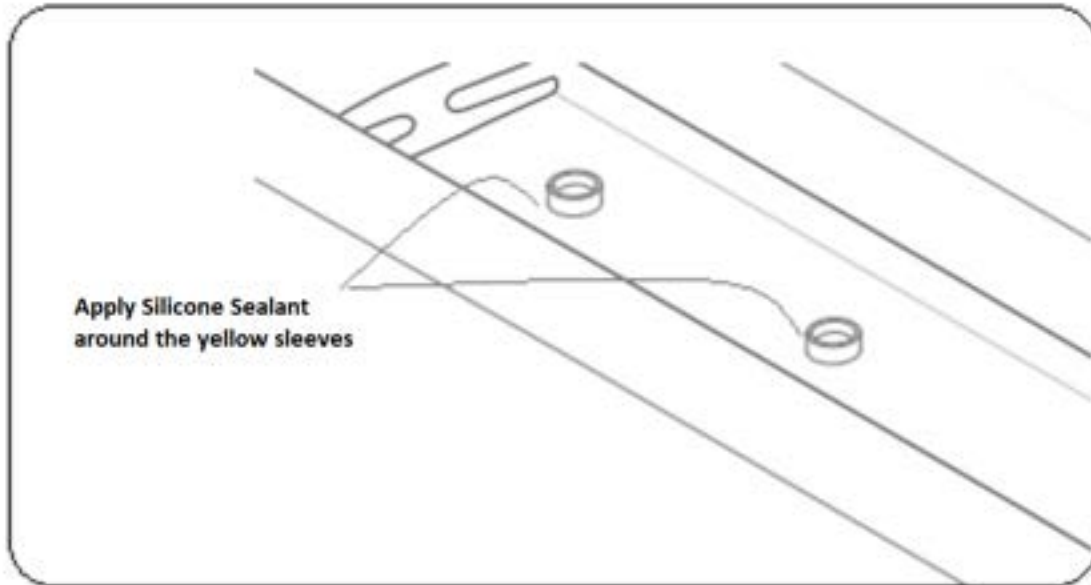



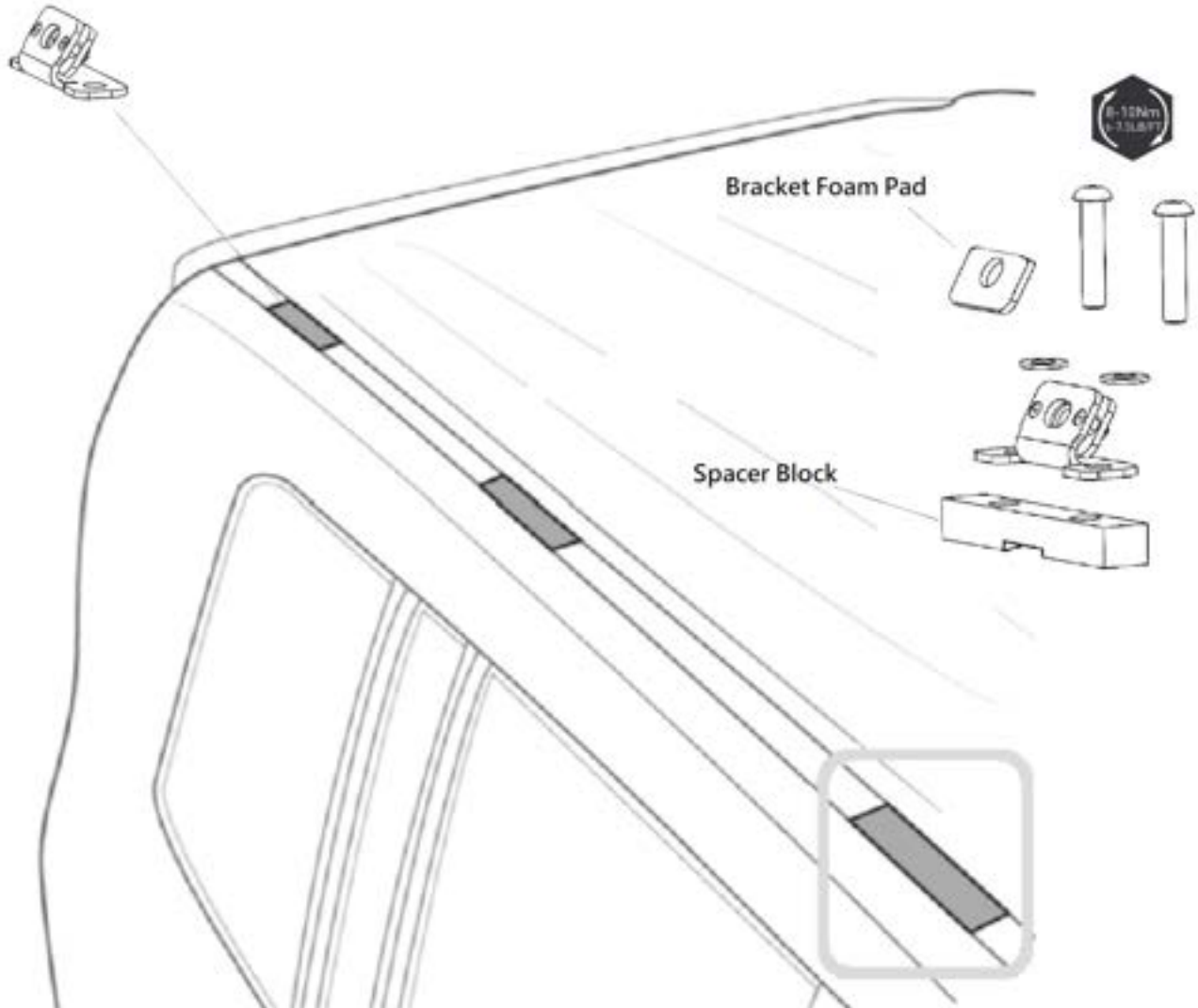

C. Installation:

- Place the Black HDPE Spacer Blocks over the threaded holes
 - Place the X-Bracket over the Black HDPE Spacer Blocks
 - Fit the following fasteners loosely into the securing holes:
 - M8 x 40mm Button Cap Socket Screws x 2 pcs per bracket
 - *Apply silicone generously around the thread prior to installation
 - $\frac{5}{16} \times \frac{3}{4}$ Flat Washers x 2 pcs per bracket
 - Align all the X Brackets in a straight line with the aid of a straight edge.
(*Tips: Use the flat side of the Tough Bar as a straight edge to align the X brackets by pushing the Tough Bar gently toward the centre of the vehicle)
 - Tighten all fasteners to 8-10Nm (6-7.5lbs/ft)
 - Place the Bracket Foam Pad over the X Bracket
- *** Do not apply downward force while tightening the X Bracket to avoid causing the Internal Threaded Roof Plate from dislodging.**

*Note: XAB40_LCR at the rear



 Warning	XAB40 For middle & front	XAB40_LCR For rear only
<p>Please note brackets are different and must be placed in the correct locations when installing!</p>	 <p>Notch</p> 	 <p>Flat</p> 

Step 2: SETTING UP TOUGH BAR ON ROOF-RACK

- Apply Acoustic Foam Tape onto the flat face of the Tough Bar where fasteners are not present (See illustration below)

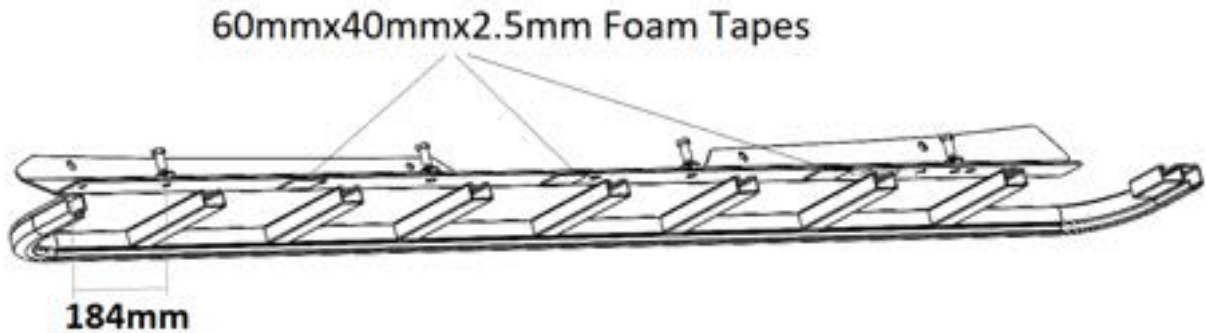

- With the TLRAL22/FT/OE Roof Rack upside down, position the flat surface of the Tough Bars on the underside of the Roof Rack as shown above.

(Tips: Start by positioning the 2nd hole from the rear of the Tough Bar, onto the 1st Channel Cross Bar from the rear of the Roof Rack. The arrow on the Tough Bar must point toward the front of the vehicle)

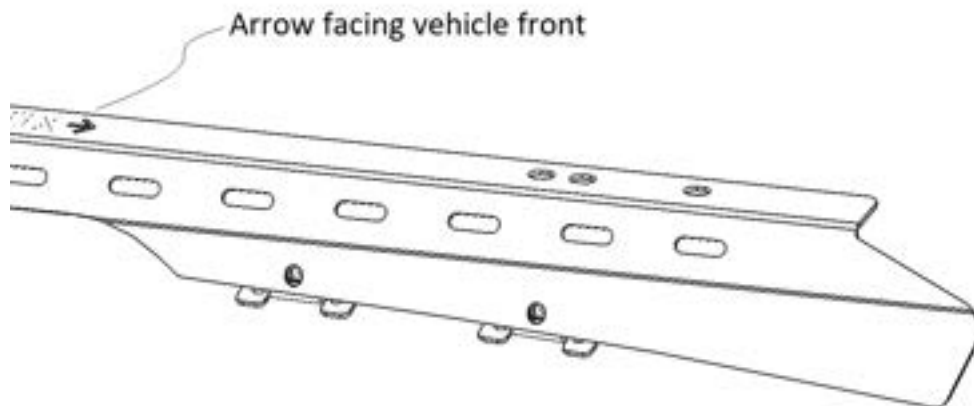

- Install all the M10 Hex Bolts, M10 Star Washers, $\frac{3}{8}$ x1 washers and Strut Nuts to the prescribed locations on the Tough Bar. (Tips: Do not tighten until adjustment is completed)

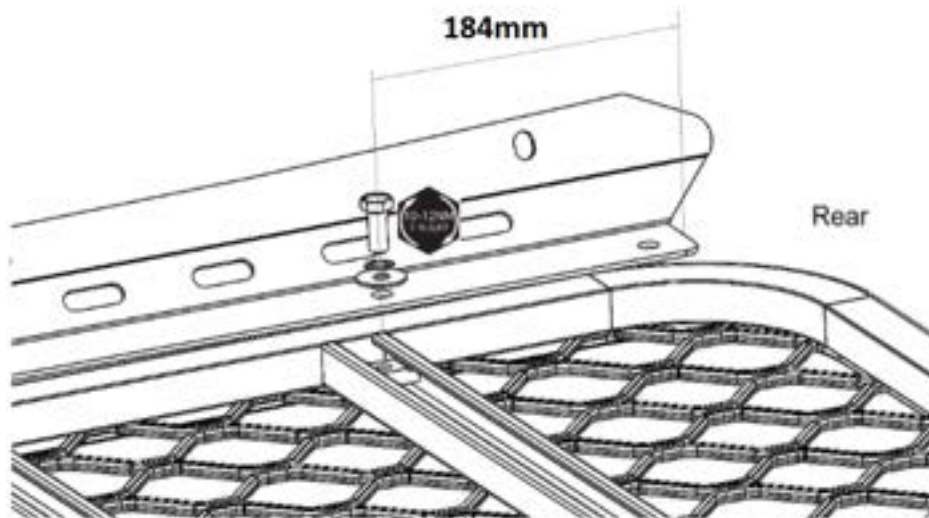

- Move the Tough Bars evenly both sides of the Centre Line to achieve **Overall Width distance at the front and rear most mounting position**. Tough Bars must be spaced evenly on both sides of Roof Rack. Once the Tough Bars are in position, tighten the M10 x 25 Hex to 10-12Nm (7-9lbs/ft)
- Measure the external width of rear and front X Bracket as shown below:

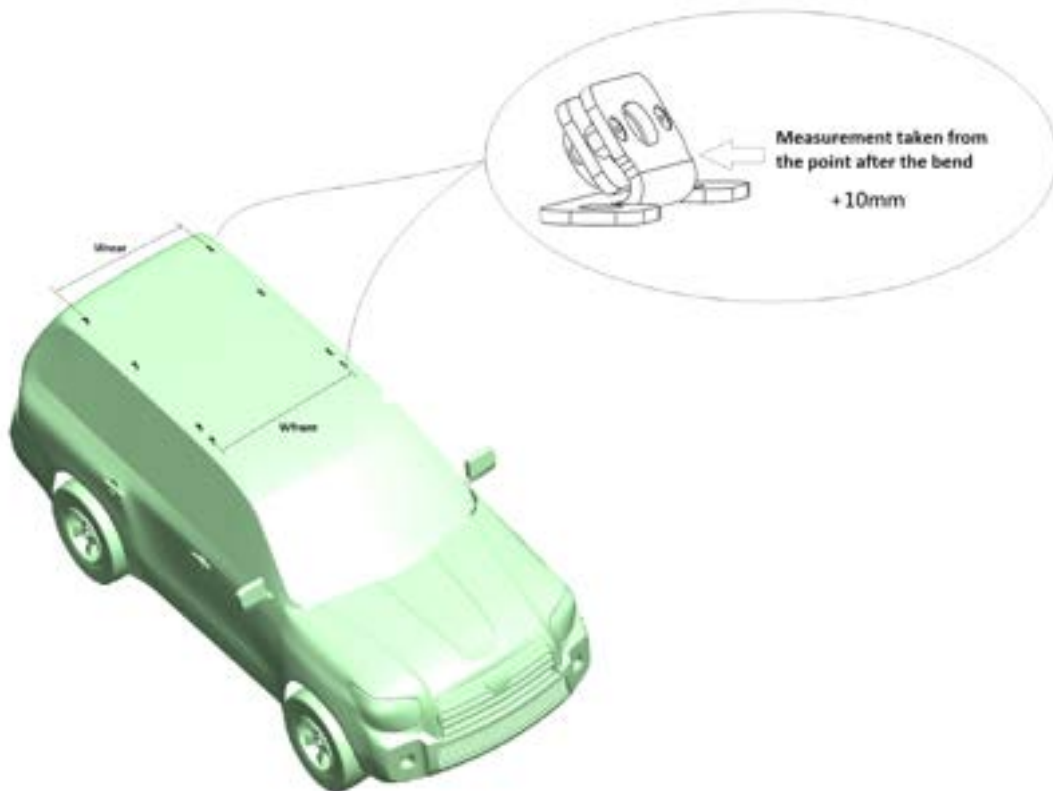

- Set the Overall Width at the front and rear mounting point on the Roof Rack as shown below:

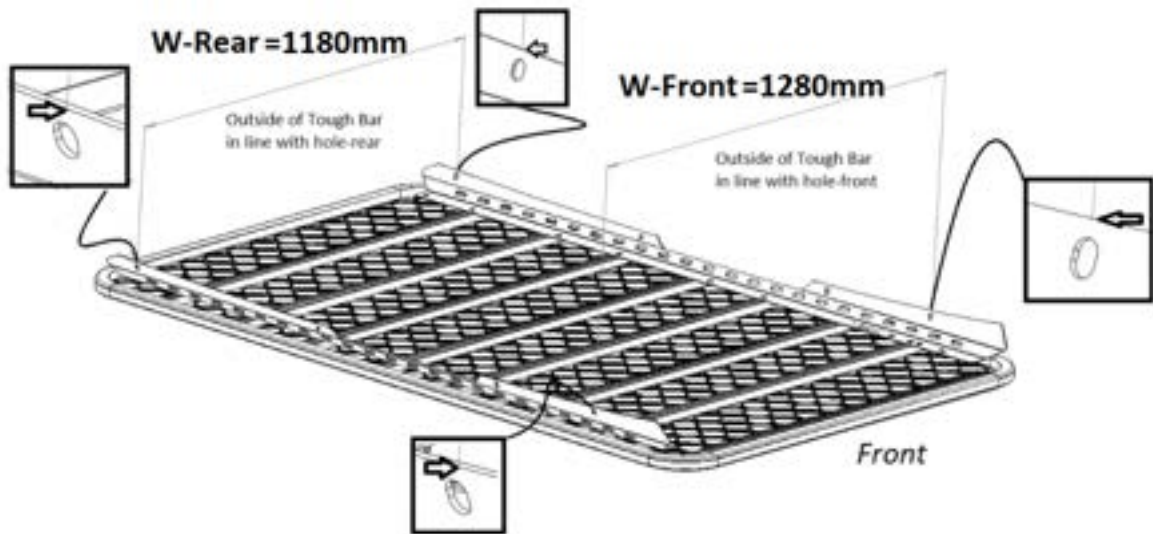

D. Installation of Wind-deflector(TLRWD15X)

- Apply Acoustic Sponge Tape on to the Roof Rack Frontal Area

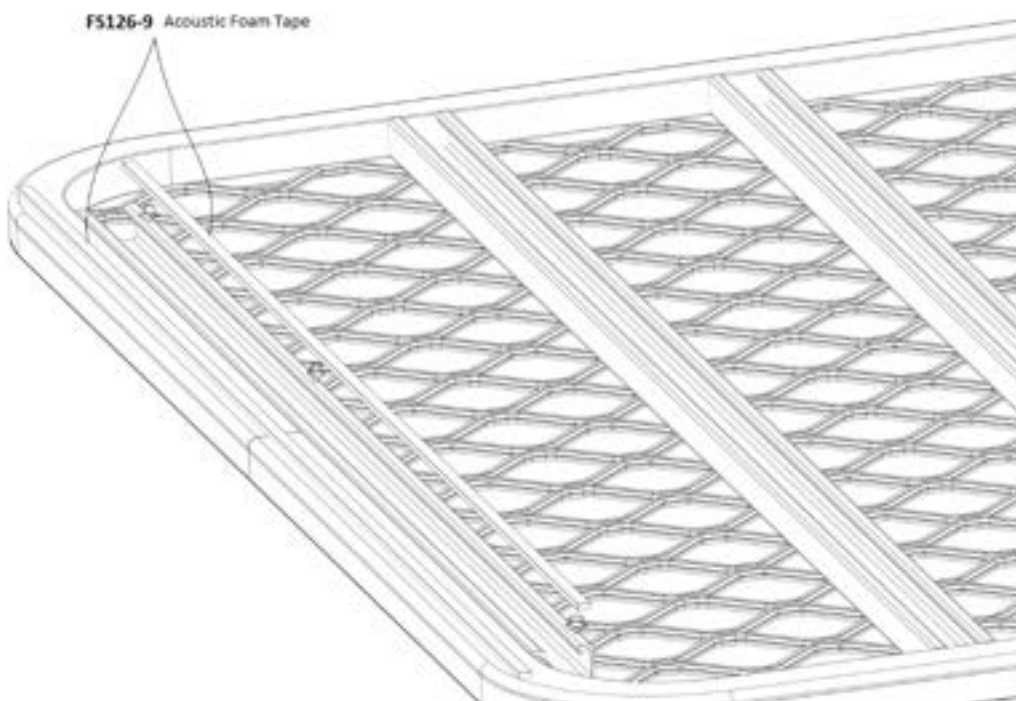

- Secure the Wind-deflector onto the front of the rack as per the illustration shown

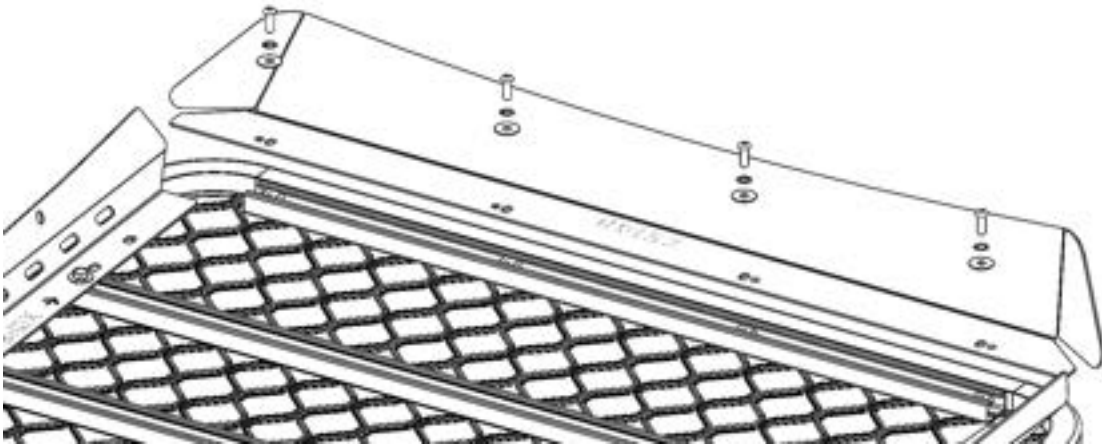

below:

- Centralised and tightened.

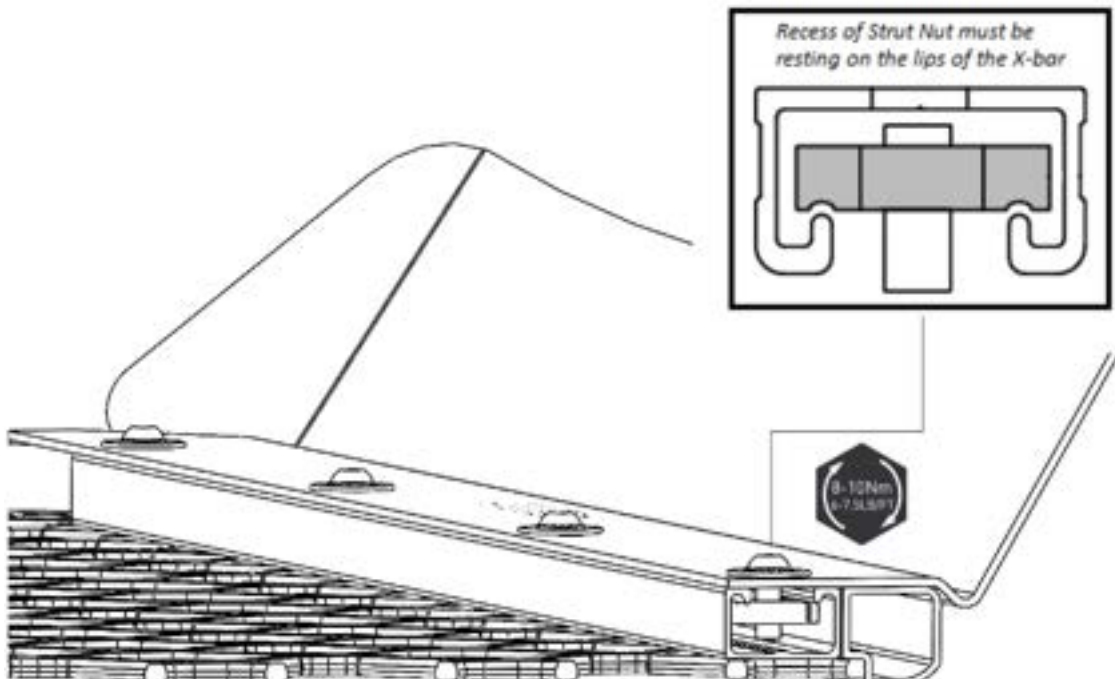

Step 3: Installation of Roof-rack assembly

E. Attach the Roof-rack assembly onto the X Bracket

- With a person either side of the Roof Rack, carry the Roof Rack over the rear of the vehicle and rest the Tough Bar gently over the X Brackets and align the hole centres.

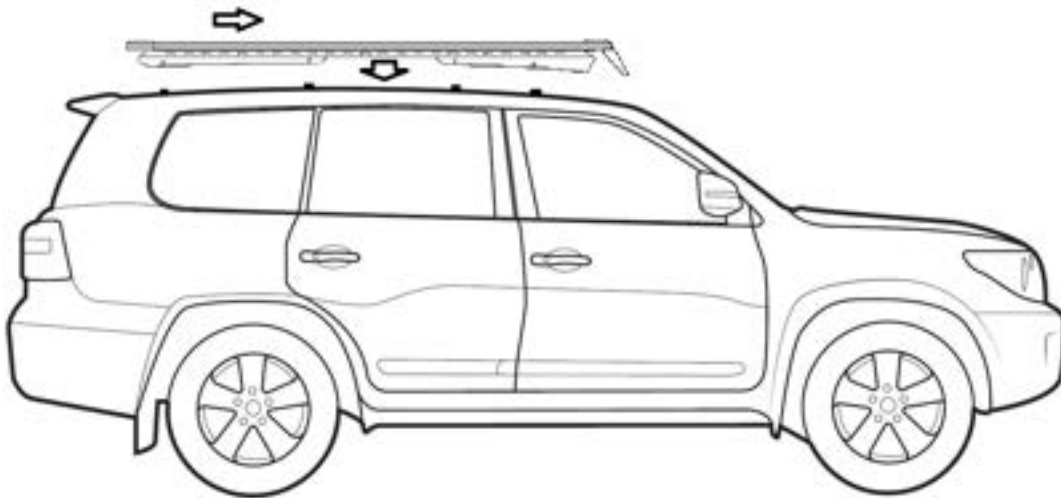

- Fit the M10x25 Button Cap Socket Screw with $\frac{3}{8}$ x $\frac{3}{4}$ Flat Washer through the holes and tighten to 10-12Nm (7-9lbs/ft)

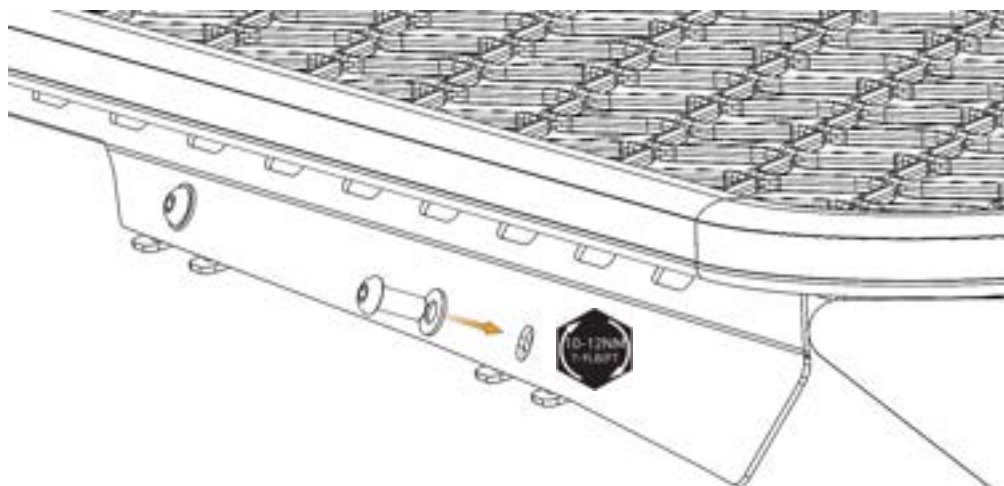

- Check to ensure that all fasteners are fully secured.
- The installation is now completed and ready to be used.

SAFETY

- Cargo must be secured firmly onto the Roof Rack during operation at all times.
- Frequently check the tightness of cargo on the Roof Rack, especially when travelling over rough terrain or off-road
- Use only non-stretchable fastening ropes or straps to attach cargo onto the Roof Rack.
- Extreme care must be taken in off road conditions.

MAINTENANCE

- All bolted connections should be checked after driving a short distance when you first install your roof racks
- All bolted connections should be checked at regular intervals, depending on road conditions, usage, loads and distances travelled
- All bolted connections should be checked each time they are re-fitted.

IMPORTANT WARNING!

IT IS CRITICAL THAT ALL TRACKLANDER 4WD ROOF RACK PRODUCTS BE PROPERLY AND SECURELY ASSEMBLED AND ATTACHED TO YOUR VEHICLE. IMPROPER ATTACHMENT COULD RESULT IN AN VEHICLE ACCIDENT, AND COULD CAUSE SERIOUS BODILY INJURY OR DEATH. YOU ARE RESPONSIBLE FOR ASSEMBLING AND SECURING ALL TRACKLANDER 4WD ROOF RACK PRODUCTS TO YOUR VEHICLE, CHECKING THE ATTACHMENTS PRIOR TO USE, AND PERIODICALLY INSPECTING THE PRODUCTS FOR ADJUSTMENT, WEAR AND TEAR. THEREFORE, YOU MUST READ AND UNDERSTAND ALL OF THE INSTRUCTIONS AND PRECAUTIONS SUPPLIED WITH YOUR TRACKLANDER 4WD ROOF RACK AND ACCESSORIES PRIOR TO INSTALLATION OR USE. IF YOU DO NOT UNDERSTAND ALL OF THE INSTRUCTIONS AND WARNINGS, OR IF YOU HAVE NO MECHANICAL EXPERIENCE AND ARE NOT THOROUGHLY FAMILIAR WITH THE INSTALLATION PROCEDURES, YOU SHOULD HAVE THE PRODUCT INSTALLED BY A PROFESSIONAL INSTALLER OR OTHER QUALIFIED PERSON.

NOTE: TRACKLANDER 4WD ROOF RACKS will not be responsible for any damage caused by the failure to install the product according to these instructions. Please call us if you have any questions about the installation of this product.

TRACKLANDER 4WD ROOF RACKS

T : (08) 9451 0700 E :sales@tracklander.com.au W :tracklander.com.au

A:12 Railway Parade, Welshpool, WA 6106

OPEN 8.00AM - 5.00PM MON-FRI